

Atlantic Vertical Plus Glass Washers



The Atlantic Plus Washer models are the company's most popular machine and workhorse. Insulated glass producers and glass processors alike enjoy the flexibility and ease of maintenance of these machines.



ATL-V Plus-21-4B

FEATURES

- ▶ Machine frame built in strong stainless box section
- ▶ Fully hinging stainless doors and tank hatch for easy access
- ▶ Internal and external viewing screens
- ▶ 2 stage models with wash and rinse capacity of 150 litres
- ▶ Automatic driven in and outfeed racks
- ▶ Working height 760mm (bottom edge of glass)
- ▶ Hot wash and rinse
- ▶ Variable running speed with inverter drive
- ▶ Additional water pump for final rinse filtration
- ▶ Noise reduction, roll on/off induction cover
- ▶ Lighting panel on outfeed rack
- ▶ Safety isolator switches on all doors
- ▶ Low water cut-out switch
- ▶ Choice of running direction

OPTIONS

- ▶ 4 – 6 brush conversion
- ▶ Choice of rotary brushes
- ▶ 3 – 19mm glass processing modification
- ▶ Optional rack sizes
- ▶ Conveyorised racking for small glass, minimum 210 x 100mm
- ▶ Extra sound reduction

Atlantic Vertical Plus Glass Washer Models

Atlantic Vertical Plus							A	B	C	D	E			
Machine Type	Washable Height (mm)	Brushes	Tanks Wash Stages	Top Design	Length (mm)	Glass Thickness (mm)	Conveyorised		Overall Height (mm)	Overall Length (mm)	Overall Depth (mm)	Speed m/min	Weight (Kg)	Power (kW)
							Input (mm)	Output (mm)						
ATL-V Plus-13-4B	1300	4	2	Open	200	3-12	2000	2400	2150	5880	1000	1-8	1000	11
ATL-V Plus-15-4B	1500	4	2	Open	200	3-12	2000	2400	2350	5880	1000	1-8	1100	12
ATL-V Plus-18-4B	1800	4	2	Open	200	3-12	2400	3000	2800	6880	1000	1-8	1200	12
ATL-V Plus-21-4B	2100	4	2	Open	200	3-12	2400	3000	3250	6880	1000	1-8	1350	13.5



ATL-V Plus-15-4B Atlantic Plus, 1-5 metre, 4 brush

Atlantic Plus Models

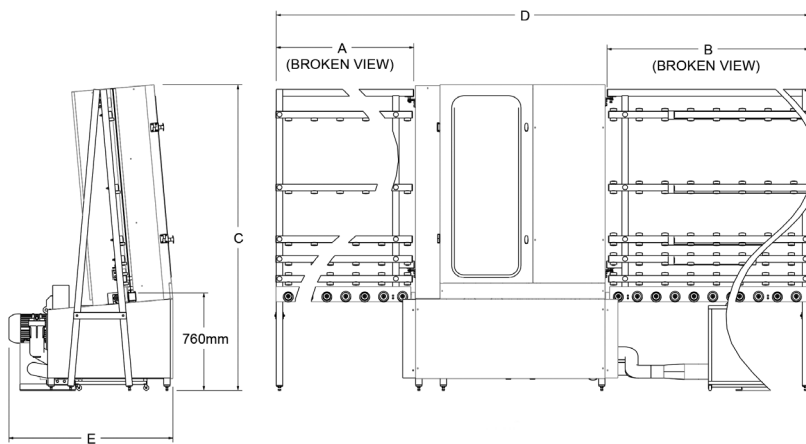
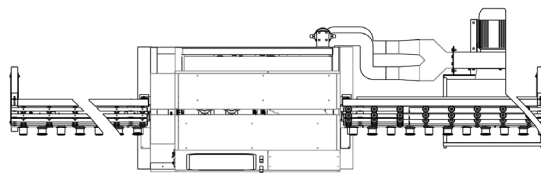

All stainless components and easy access make maintenance easy and downtime low.



Safety interlocks on all doors

CONTACT

SALES

☎ 01455 251151

✉ sales@atlantic-machinery.co.uk

STUART HEADINGTON

☎ 07803 758291

✉ s.headington@atlantic-machinery.co.uk